



333 Bayview Avenue
Amityville, New York 11701

For Sales and Repairs, (800) 645-9445
For Technical Service, (800) 645-9440

Publicly traded on NASDAQ Symbol: NSSC

FREEDOM 64 Wireless

F-64TP Touchpad, F-LTRANS and F-TAB INSTALLATION INSTRUCTIONS

© NAPCO 2006

WI1499A 9/06

GENERAL DESCRIPTION

The NAPCO Freedom 64 Deadbolt-Activated Home Protection System, a revolutionary new concept in residential security, combines intuitive interactive arming with a passive disarming scheme, providing a system which is not only effortless to use, but also 100% false alarm resistant during the critical arming and disarming sequences.

The system is armed with a simple push of a button (**STAY** or **AWAY**) on the F-64TP Touchpad control module, followed by the locking of the home's deadbolt. To disarm, simply unlock the deadbolt.

The microprocessor controlled F-64TP Touchpad receives information regarding the status of the deadbolt and door through its integral receiver, from the F-LTRANS wireless transmitter and an integral PIR sensor to ensure fool-proof operation. With the Touchpad's integrated voice prompt speaker and 2-line LCD window, interacting with the system is easy and trouble-free. The Touchpad includes an integral burglary and fire alarm siren. A single Touchpad siren meets the audibility requirements of UL985 (Residential Fire) and UL1023 (Residential Burglary).

The F-LTRANS wireless transmitter determines the status of the deadbolt (locked or unlocked) through the F-TAB deadbolt sensor, which is installed in the deadbolt strike hole. The door status (open or closed) is supplied to the F-LTRANS wireless transmitter via a recessed door contact sensor (not provided) wired into it. This information is transmitted to the wireless receiver inside the F-64TP Touchpad, and is used to arm and/or disarm the system. The Touchpad then clearly displays the monitored door status ("Open", "Unlocked", etc.) in its LCD window. There are no moving parts in the F-TAB deadbolt sensor to break or wear out; its adaptive inductive system ensures trouble free use. If the position of the bolt in the deadbolt strike hole changes over time due to the door sagging, deadbolt replacement, etc., the Touchpad microprocessor will automatically account for, and make, the necessary adjustments for these changes.

The F-64TP Touchpad's integral wide-angle UL-approved PIR motion sensor acts as an occupancy sensor that provides the microprocessor with activity information which prevents the user from making errors during the critical exit and entry periods. For example, if the User presses the AWAY button, opens and closes the door and locks the deadbolt but does not leave, the PIR will sense the User's presence in the home and automatically default

to STAY mode arming, preventing a false alarm.

If the system is armed in the AWAY mode, the F-64TP Touchpad PIR will generate an alarm if an intruder is detected. After an intruder has been detected, the system may only be silenced by inserting the I-FOB digital key into the I-FOB slot on the F-64TP Touchpad.

By allowing this level of system control without traditional numeric keypad interaction, the NAPCO Freedom System will provide a significant reduction in false alarms due to user error and also provide comfortable use of the system to those customers whose technophobic tendencies would prevent them from arming and disarming the system using a traditional keypad.

The NAPCO Freedom 64 System is also designed to prevent the arming of the alarm system if all deadbolts are not engaged, a high security feature normally found only in very elaborate high-end installations.

The F-64TP Touchpad is one of 4 Touchpad designs within the NAPCO Freedom 64 Home Protection System. The three other Touchpad designs include:

- **F-64TPG***: Garage Door Touchpad (See WI1508)
- **F-64TPBR***: Bedroom Touchpad (See WI1505)
- **F-64TP-H***: Hardwired Touchpad (See WI1518)



INTEGRAL WIRELESS RECEIVER

The F-64TP Touchpad incorporates an integral RF receiver. This receiver receives transmissions ONLY from the F-LTRANS wireless transmitter (no other transmitters will work with this receiver). The system uses two different frequencies to reduce "nulls" and prevent noise on a single frequency from disrupting communication. Rolling codes are also used to prevent transmissions from being recorded and re-transmitted to defeat the system.

The minimum free air distance is about 600 feet, but walls and other obstructions may significantly reduce this distance. This Primary transmitter should never have a range problem as it should be placed within the same room as the Touchpad as required for the integral PIR to protect the interior deadbolt latch. However, the signal range should be taken into account when considering the use of a second transmitter to optionally protect a second door / deadbolt.

INTEGRAL 4 ZONE EZM

With each Touchpad containing an integral 4 zone EZM, and with a maximum of four Touchpads al-

*Not evaluated by UL.

lowed per system, a total of 16 zones may be added to the system using Touchpads. Three GEM-K1CA keypads can also be added (each with an integral 4 zone EZM) adding 12 additional zones for a total of 28 zones from Touchpads and keypads. Additional GEM-EZM's and/or GEM-EZM4-8's can be added, thus maximizing the capacity of the F-64 control panel to a grand total of 64 zones within the system.

INSTALLATION OVERVIEW

The NAPCO Freedom System utilizes the home's existing deadbolts and requires only that the F-TAB deadbolt sensor be installed into the deadbolt strike hole in the door jamb. This sensor is compatible with all 3/4" diameter deadbolts with a 5/8" throw or greater. Simply remove the strike plate and dust cup, run the 2 conductor wire from the deadbolt hole to a F-LTRANS wireless transmitter, and insert the F-TAB deadbolt sensor into the strike hole. The Touchpad installs on a 4-wire bus and also includes an integral burglary and fire alarm siren that produces 85dB (at 10 feet) as required for UL Residential Burglar and Fire. The Touchpad does not have to be located next to the door, but can be mounted anywhere that allows the integral PIR to "protect" the door latch with its PIR, and allows the user to hear the siren chirp when exiting and arming Away. The F-LTRANS wireless transmitter is typically mounted adjacent to the doorframe. It may be mounted high enough to be unobtrusive, yet accessible for inspection and battery replacement.

The Touchpad includes a 4 zone EZM and an optional input for the Secondary door transmitter. In less time than it takes to install a traditional keypad, this comprehensive module consisting of the Touchpad, deadbolt sensor, door contact, motion sensor and siren can be installed.

NOTE: If protecting a door with glass panels or side lights, an acoustic glass-break sensor (connected to the Touchpad Expansion Zone) should be installed to insure the integrity of the system.

POWER

The F-64TP Touchpad is powered by the keypad bus of the F-64 Control Panel. Each Touchpad draws 70mA at 11.7-12.5VDC and an additional 140mA in alarm for a total of 210mA maximum current. The standby current may be reduced by cutting jumper "W1". Deduct these values from the system standby current and alarm current, as described in the wiring diagram.

SELECT SYSTEM CONFIGURATION

The first task is to determine where the Touchpad will likely be installed, and what kind of system configuration you will need:

- **Install a wireless Touchpad with a Primary and/or a Secondary transmitter** (continue with these instructions)
- **Install a hardwired Touchpad without any transmitters** (purchase Touchpad F-64TP-H and see WI1532)
- **Installing additional wireless Touchpads** (see page 7, step 17.

PRIMARY AND SECONDARY TRANSMITTERS

The primary transmitter that is located in the same room as the Touchpad *and its jumper must NOT be installed.*

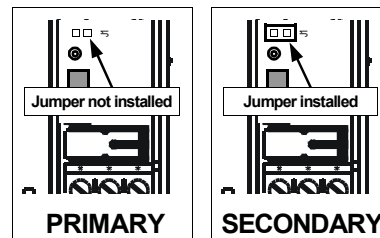

If there is a secondary transmitter installed, it **MUST** have a jumper placed on the Address jumper.

The factors considered when selecting the type of Touchpad are based primarily upon the installation environment, however the similarities and differences should be noted.

The wireless and the hardwired Touchpads both require direct wiring to the control panel and are equivalent in that they both provide the same protection and operate in the same manner. Although they both require the installation of the F-TAB deadbolt sensor and a door sensor, the hardwired system requires these sensors be wired directly to the hardwired Touchpad. The wireless system only requires the F-TAB and door sensor be wired directly to the *L-TRANS transmitter*, thus providing more flexibility when selecting Touchpad mounting locations. The hardwired Touchpad requires that it be mounted adjacent to the primary exit/entry door. The wireless Touchpad can be mounted anywhere that allows the integral PIR to "protect" the door latch with its PIR, and allowing the user to hear the siren chirp when exiting and arming Away. The wireless Touchpad also allows for two doors to be protected with one Touchpad.

If you choose to install a wireless Touchpad with Primary and/or Secondary transmitters, please take a moment to read the following notes regarding transmitters and how the system is designed to work with them.

WIRELESS TRANSMITTERS

Each wireless F-64TP Touchpad can support up to two F-LTRANS wireless transmitters (thus each F-64TP wireless Touchpad can supervise two doors). Up to 4 Touchpads can be installed in the system. **Note:** The Secondary door does not allow arming egress; only the primary door can be used to complete the arming sequence.

During transmitter programming ("learning") process, the Touchpad recognizes the presence or absence of the jumper located inside the transmitter(s). **For a single Touchpad installation with two doors protected by two transmitters**, one transmitter must be configured as a Primary (NO shunt connector installed into the address jumper) and the other transmitter must be configured as a Secondary (with the shunt connector installed). The Primary transmitter should always be installed to protect the door used to ARM the system and EXIT the premises. The Secondary transmitter should be used to protect a second door that will be used only for ENTRY (or to disarm when armed Stay).

Although the Secondary door can, in theory, be used as an exit door, to do so you must always be certain the Primary door deadbolt is locked before arming, thereby defeating the foolproof nature of the Freedom system. Further, the Touchpad LCD text will NOT display the status of the Primary door deadbolt (the Touchpad LCD text will ONLY display the status of the Secondary door deadbolt). Therefore, *pressing Away and exiting through the Secondary door (with the Primary door deadbolt remaining unlocked) will result in the system remaining unarmed.* As a result, the homeowner should be instructed to use the door protected by the Secondary transmitter FOR ENTRY ONLY (or to disarm when armed Stay).

Similarly, with a single F-64TP Touchpad installation with one exit door protected by one transmitter, the position of this protected deadbolt alone—locked or unlocked—will not affect the ability to initiate the process of arming the Touchpad. This is designed to allow the homeowner to press AWAY or STAY (starting the arming process) with the exit door open and/or unlocked.

Furthermore, because the Touchpad integral PIR will seldom be able to supervise the Secondary transmitter, care must be taken to ensure an intruder can not disarm the system by turning the deadbolt latch at the Secondary transmitter. Using an additional PIR to generate an alarm before the intruder can turn the deadbolt latch may not be sufficient (standard PIR's false alarm features may cause it to take too long to detect an intruder). *Additional perimeter and/or interior intruder detection devices, such as window foil, glass breaks or additional PIR's, may be required to ensure the intruder will be detected by the system before the deadbolt latch at the Secondary transmitter can be thrown.* **Note:** If the Secondary transmitter deadbolt (or any other monitored deadbolts in the system) are unlocked, the Touchpad LCD text will indicate the unlocked doors. Therefore all monitored deadbolts (except at the primary door) **must** be examined and locked before the system can be armed.

INSTALLATION PROCEDURES

After installing the F-64 control panel, turn to page 5 and begin the procedures necessary for:

- Wiring and mounting the Touchpad
- Mounting and wiring the F-TAB sensor
- Wiring the door sensor to the F-LTRANS
- Learning the transmitters (if installed)
- Testing the transmitter strength

After completing the procedures on page 7, return to this section to configure the other options necessary for each Touchpad installed in the system, as detailed in the next section **Configuring the Touchpad**, below.

A. CONFIGURING THE TOUCHPAD

If not in already, enter **Touchpad Configuration Mode** by placing the F-64 panel jumper in Configuration Mode, the Touchpad LCD text will display "OUT OF SYSTEM" within a few seconds (you can also press and hold the **STAY**, **BYPASS** and **YES** buttons until the system reboots or wait for a 60 second timeout). Press and hold **MENU** for 2 seconds to enter Touchpad Configuration Mode.

Once the Touchpad Configuration Mode is accessed, all messages will display in the order shown below (press **MENU** to scroll through the list or press **RESET** to exit). For more complete information, see the F-64 panel programming instructions, WI1502. :

- KEYPAD BEEP
- ENTRY SOUNDER
- BACKLIGHT FOLLOW PIR
- BACKLIGHT BRIGHTNESS
- AMBUSH INTERVAL
- AMBUSH SOUNDER
- KEYPAD ADDRESS.
- EZM ADDRESS
- ZONE RESPONSE
- TAMPER DETECT
- DISABLE PIR
- PRE AWAY/STAY
- LEARN PRIMARY
- LEARN SECONDARY
- CLEAR ALL LEARNED TXS
- DISPLAY RF SS
- DISPLAY RF NOISE

B. EASY MENU DRIVEN PROGRAM MODE

Temporarily replace the F-64TP Touchpad addressed as "01" with an F-64PROG programmer, and program the panel using the *Easy Menu Driven Program Mode* (or use PCD-Windows Quickloader Download software). See programming instructions WI1502 for complete details.

C. CREATE THE MASTER I-FOB

Note: Only one Master I-FOB can exist within the system. The Master I-FOB is the first I-FOB enrolled in the system and is installed in User Slot 1. The Master I-FOB is used to enroll additional I-FOB's in all 4 Areas. The Master I-FOB should be given to the customer after installation.

To enroll a Master I-FOB on a **new** system:

1. Remove power from the system, wait 10 seconds, then power up the system.
2. Within one minute after power up, press **MENU** on the Touchpad to enter "Touchpad Menu Mode".
3. Press **MENU** repeatedly until the Touchpad reads "ACTIVATE PROGRAM Y/N". Press **YES** to enter the "User Program Mode".
4. Press **MENU** until the Touchpad reads "CREATE MASTER I-FOB Y/N". Press **YES**.
5. Insert the I-FOB with the red label that reads "IFOB MASTER SILENCE KEY" into the I-FOB keyhole located on the face of the Touchpad.
6. The Touchpad window will display, "MASTER ENROLLED ENROLL USER?" Press **NO** to continue.
7. Remove your newly created Master I-FOB and press **RESET** to exit the Program Menu.

D. TEST EACH TOUCHPAD PIR

Insert the newly created Master I-FOB into the Touchpad and enter the Touchpad Menu Mode by pressing **MENU**. Press **NO** until "ACTIVATE PIR TEST" appears in the LCD window and perform a test of each Touchpad PIR.

E. TEST THE SYSTEM

After completing all tasks, perform a test of the entire system, including all Touchpads, deadbolts and transmitters.

PANEL PROGRAMMING OVERVIEW

For proper system operation, the F-64 control panel is pre-programmed at the factory with the features listed below. The features listed below are presented here for informational purposes only--NO additional programming is needed--there is no need to enter Direct Program Mode and make additional changes unless special conditions of the installation require additional programming as determined by the installer.

- F-64 Control Panel:** "Disable Code-Required for EZ Bypass" enabled (address 1424; in PCD-Windows Quickloader, this feature is located in the **Keypad Features** screen).
- F-64 Control Panel:** "Interior Normally Bypassed Mode" enabled (address 1422; in PCD-Windows Quickloader, this feature is located in the **System Options** screen). Enabling this feature prevents STAY zones from scrolling in the Touchpad LCD window.
- F-64TP Freedom 64 Touchpad:** "Easy Arming" enabled in keypads 1-7 (addresses 1440-1446; in PCD-Windows Quickloader, this feature is located in the **Keypad Assignment** screen).

Features numbered 4, 5 and 6 listed below are automatically configured from the factory, and also when the F-64PROG programmer is used to program zones. In PCD-Windows Quickloader Download software, these features are located in the **Zone Assignment** screen:

- Zone Type:** Every mapped Door Zone is a "Freedom Door" zone type.
- Zone Type:** Every mapped PIR Zone is a "Freedom STAY" zone type.
- Zone Type:** Every Non-STAY (Interior), Non-24-Hour, Non-Day Zone is a "Freedom Perimeter" zone type.

Door Type Attributes:

PRIORITY, SELECTVE BYPASS, BURG OUTPUT, E/E, AUTO-RESET, and SWINGER SHUTDOWN

Not Programmed:

No EOL, AUTO-BYPASS, Priority with Bypass,

All Interior (STAY) zones including the mapped integral PIR should be programmed with:

AUTO-BYPASS, AUTO-BYPASS RE-ENTRY, SELECTIVE BYPASS, BURG OUTPUT, AUTO-RESET, SWINGER SHUTDOWN, E/E FOLLOWER, STAY and POWER UP DELAY.

See the chart below and the programming instructions WI1502 for more information regarding these pre-programmed features:

FREEDOM-64 ZONE TYPES

Freedom F-64 Zone Type	Priority	Auto-Bypass	Auto-Bypass Re-entry	Selective Bypass	Burg Output	E/E1	E/E2	E/E Follower	Chime	Chime 2	Report Alarm Tel1	Report Alarm Restore Tel1	STAY (Interior)	Perimeter Group Bypass
Perimeter	Y			Y	Y									Y
Perimeter (Telco 1)	Y			Y	Y						Y	Y		Y
Door E/E1	Y			Y	Y	Y								Y
Door E/E1 (Telco1)	Y			Y	Y	Y					Y	Y		Y
Door E/E1 Chime	Y			Y	Y	Y			Y					Y
Door E/E1 Chime (Telco1)	Y			Y	Y	Y			Y		Y	Y		Y
Door E/E2	Y			Y	Y		Y							Y
Door E/E2 (Telco1)	Y			Y	Y		Y				Y	Y		Y
STAY (Interior) Follower		Y	Y	Y	Y			Y					Y	
STAY (Interior) Follower (Telco 1)		Y	Y	Y	Y			Y			Y	Y	Y	
STAY (Interior) E/E1		Y	Y	Y	Y	Y							Y	
STAY (Interior) E/E1 (Telco1)		Y	Y	Y	Y	Y					Y	Y	Y	
STAY (Interior) E/E2		Y	Y	Y	Y		Y						Y	
STAY (Interior) E/E2 (Telco1)		Y	Y	Y	Y		Y				Y	Y	Y	

INSTALLING A WIRELESS TOUCHPAD, F-TAB SENSOR AND THE WIRELESS TRANSMITTER(S)

MOUNT AND WIRE THE TOUCHPAD

1 With power to the control panel off, open the F-64TP Touchpad. Remove the front of the Touchpad housing by inserting a screwdriver into the (2) slots in the bottom of pad. Twist screwdriver to remove cover.



2 Mark the holes.

The Touchpad can be mounted anywhere, provided its PIR directly supervises the deadbolt latch on the protected door. **Note:** Select a location that will allow the antenna to be positioned straight down as shown in Step 3.

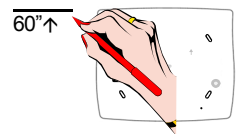

Place the template against the selected wall at a height of approx. 60" (to the top of the Touchpad).

Mark or punch through the 4 oval mounting holes, the wire access opening, and the hole for the antenna.

3 Cut wire access opening

Install 4 wall anchors and cut wire access opening in wall. Pull the 4 conductor bus wire from the wall out of the access hole. Be sure that the hole is located to allow the antenna wire to be positioned straight down as shown.

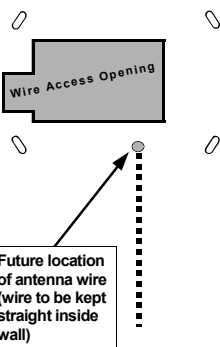

Warning: Use caution when cutting holes. There may be high voltage wiring in the wall. Wood beams may obstruct the antenna installation. Choose the location carefully.

4 Make Connections

Pull wires through base and secure base to wall. Solder or crimp bus wires to the Touchpad connector plug using the wiring diagram as a guide. Plug 4 conductor bus wire into its receptacle located at the rear of the Touchpad. While pushing excess bus wires back into wall, insert antenna wire into its hole, carefully guiding the antenna wire to a "straight down" position.

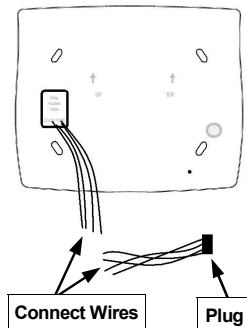

MOUNT AND WIRE THE F-TAB SENSOR AND WIRE THE DOOR SENSOR TO THE F-LTRANS

5 Use only an F-TAB deadbolt sensor as shown below.

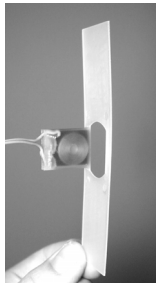

F-TAB deadbolt sensor

6 Remove the strike plate

Remove the two screws securing the deadbolt strike plate to the door frame. If there is a dust cup installed, it must be removed.

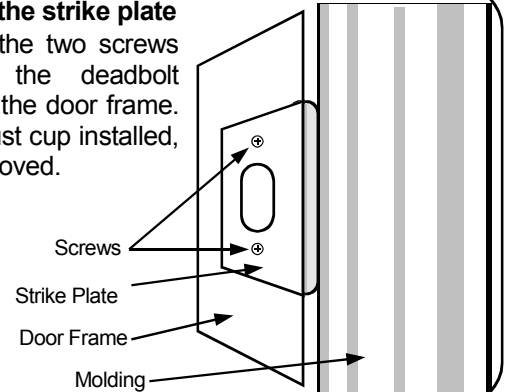

7 Test fit the F-TAB sensor into the deadbolt strike hole.

For increased kick-in protection, place the sensor "tab" closer to the inside (protected) side of the premises. Determine if the deadbolt hole will need enlarging. The F-TAB sensor requires a depth of approximately 1". In addition, one side of the deadbolt hole must be enlarged to accommodate the sensor "tab".

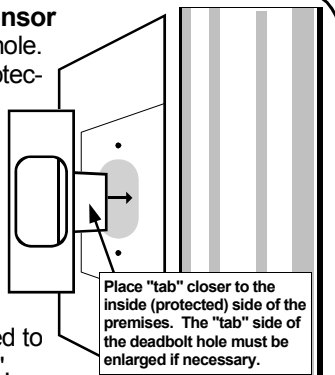

8 Enlarge the deadbolt hole using the supplied drilling guide. Secure the drilling guide to the bolt hole using the strike plate screws. With a 1/4" bit, hold the drill level and drill through the (2) holes of the guide matching the location of the sensor "tab" to a depth of approximately 1 1/2".

Remove the drill guide when done.

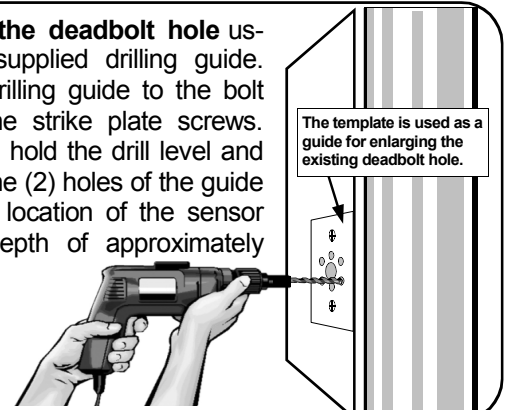

9 To increase the *depth* of the deadbolt hole, use a 1" spade bit (shown).

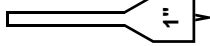

Remove the remaining wood from the deadbolt hole opening using a rotary wood rasp. The opening must not obstruct the installed F-TAB deadbolt sensor or the closed deadbolt.



10 Locate the F-LTRANS wireless transmitter:

Mount the F-LTRANS inside a drop ceiling, above the door frame, or in any location suitable for the installation (see illustration for possible locations). Using its mounting base as a template, mark the mounting holes and wire access hole (leaving at least 3/4" from the edge of the door molding to allow for the greater width of the F-LTRANS case). Drill the wire access hole as necessary.

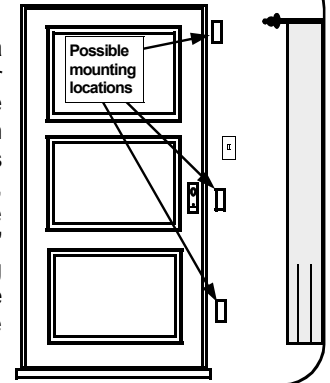

11 Drill access hole for F-TAB sensor

Drill a 3/8" hole in the deadbolt hole (A) for a two conductor wire to be run from the F-TAB deadbolt sensor to the edge of the door jamb. From this point, the wire can emerge from the wall and be placed next to the door jamb or can continue through the wall to the F-LTRANS wireless transmitter, as necessary.

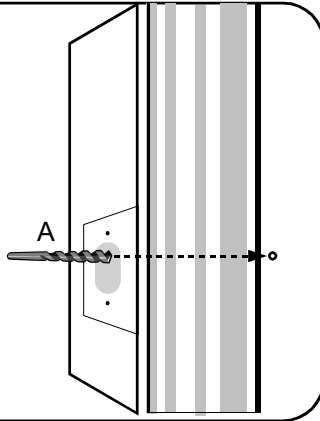

12 Drill Door Contact Hole

Drill a hole (B) for a 3/8" recessed door contact sensor. To maintain Door Kick-in Protection, the sensor must be placed on the "latch side" of the inside door frame or the top of the door frame (header). Install the door contact magnet into the door. When the door is closed, the magnet must be adjacent to the sensor. **Warning:** When drilling through door frame, always stay clear of high voltage wiring which may be present in the wall cavity.

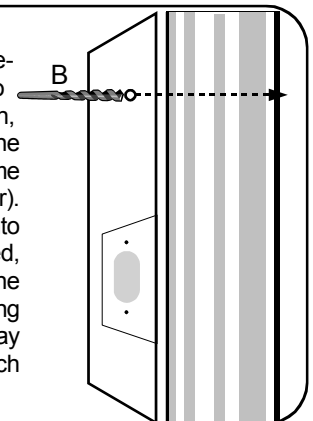

13 Install Recessed Door Contact

The door contact sensor wires must be connected to the F-LTRANS wireless transmitter.

Insert wire snake into the F-LTRANS wire access hole and out through the door contact sensor hole in the door frame. Connect the end of the sensor wires to the wire snake and pull wires into door frame and out the F-LTRANS wire access hole in wall.

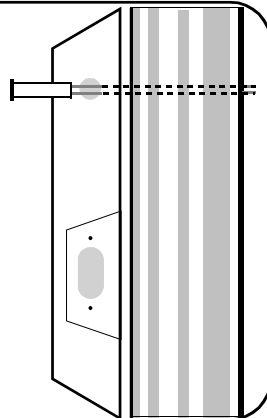

14 Install F-TAB deadbolt sensor

Using a wire snake, pull wire from the deadbolt strike hole and into the F-LTRANS wire access hole in wall. Place the F-TAB sensor into deadbolt hole. If the plastic F-TAB sensor flanges protrude past the area covered by the strike plate, it may be trimmed with a knife (see image).

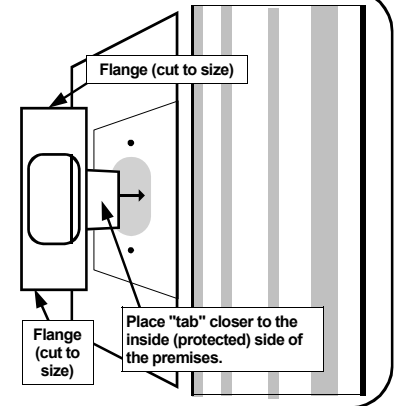

15 Install strike plate

Place strike plate over the F-TAB deadbolt sensor. Align properly over screw holes and punch through the plastic flange of the F-TAB deadbolt sensor with an awl or other sharp tool. Replace the 2 screws to secure the strike plate. Ensure that the F-TAB deadbolt sensor hole is centered in the strike plate opening.

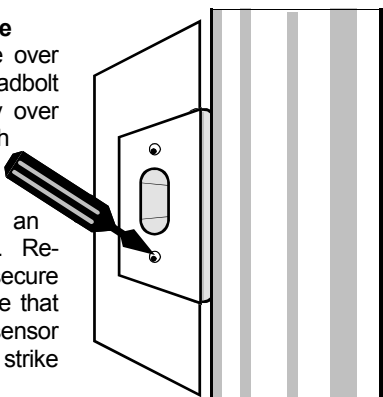

16 Install the Primary F-LTRANS

The Primary transmitter should always be installed to protect the door used to *arm* the system and *exit* the premises. (Do NOT install battery until wiring is complete). Mount the Transmitter base (screws provided) with all wires from the wall hidden under the Transmitter. Wire the F-LTRANS as follows:

- Twist together one wire from the F-TAB and one from the door contact and screw into center terminal.
- Insert remaining F-TAB deadbolt sensor wire into left terminal and secure.
- Insert the remaining door contact wire into the right terminal and secure. Do NOT install the Transmitter cover.

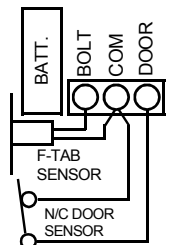

LEARN TRANSMITTERS AND TEST SYSTEM. The Primary transmitter should always be installed to protect the door used to *arm* the system and *exit* the premises. If a Secondary transmitter is needed for the installation, the Secondary transmitter should be used to protect a second door that will be used only for *entry* (or to disarm when armed Stay).

17 Multiple Transmitters--Notes

The Primary transmitter (installed in step 16) that is located in the same room as the Touchpad -- *its jumper must NOT be installed*. If a Secondary transmitter is not needed, proceed directly to step 18.

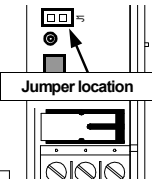

The Secondary transmitter should be used to protect a second door that will be used only for *entry* (or to disarm when armed Stay). If a Secondary transmitter is needed in the installation, install a shunt on the Secondary transmitter Address jumper. Do NOT mount the Secondary transmitter yet. **Remove all transmitter covers before proceeding and install batteries in transmitters.**

18 Deadbolt Calibration

Note: If the Primary Transmitter LED is flashing, ignore at this time).

With the Primary transmitter cover off and the battery installed, observe the Primary transmitter while performing the following steps:

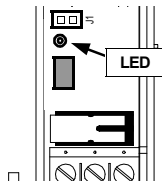

1. Open door (observe the transmitter LED flicker)
2. Close door (observe the transmitter LED flicker)
3. Lock deadbolt (observe the transmitter LED flicker)
4. Unlock deadbolt (observe the transmitter LED flicker)

The transmitter is now ready to be learned into the Touchpad receiver.

19 Prepare Touchpad to Learn Transmitters

With all wiring in place, apply power to the control panel, and the Touchpad receiver will power up. **Enter Touchpad Configuration Mode** by placing the F-64 panel jumper in Configuration Mode, and the Touchpad LCD text will display "OUT OF SYSTEM" within a few seconds (you can also press and hold the **STAY, BYPASS** and **YES** buttons until the system reboots or wait for a 60 second timeout). Press and hold **MENU** for 2 seconds to enter Touchpad Configuration Mode.

20 Learn the Transmitter(s).

While in Touchpad Configuration Mode, press **MENU** until "LEARN PRIMARY TXMIT" appears on the Touchpad LCD.

1. Press and release the Tamper Switch of the Primary transmitter (the Touchpad LCD text will read "PRIMARY TXMIT LEARNED SS#XX").
2. If installing a Secondary transmitter, stand next to the Touchpad with the Secondary transmitter in hand. Press and release the Tamper Switch of the Secondary transmitter. (The Touchpad LCD text will read "SECONDARY TXMIT LEARNED SS#XX").

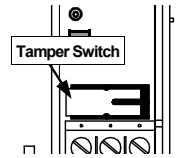

21 Test Transmitter Strength.

With the Touchpad still in Touchpad Configuration Mode, press **MENU** until "Test Transmitter Strength" appears, then press **YES**. Each time the Tamper Switch is pressed and released on either transmitter, the Touchpad LCD text will display its signal strength. Press and release the Primary transmitter Tamper Switch and make note of its signal strength ("SS#"). If used, test the Secondary transmitter signal strength in various locations until a suitable mounting location is found. Only use the Secondary transmitter to protect a second door that will be used for *entry* (or to disarm when armed Stay).

The signal strength must read above 100 on the Touchpad text to ensure transmissions are received by the Touchpad receiver accurately. If not installing a Secondary Transmitter, exit Touchpad Configuration Mode by pressing **RESET** and proceed to step 23.

22 Mount the Secondary Transmitter (if used).

Mount the Transmitter base (screws provided) with all wires from the wall hidden under the Transmitter. Wire the Secondary transmitter as follows:

- Twist together one wire from the F-TAB and one from the door contact and screw into center terminal.
- Insert remaining F-TAB deadbolt sensor wire into left terminal and secure.
- Insert the remaining door contact wire into the right terminal and secure. Do NOT install the Transmitter cover.

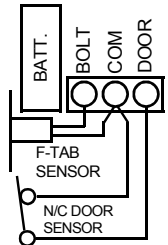

23 Re-Test Both Transmitters

1. Close all protected doors. The Touchpad should read "READY".
2. Press **STAY**.
3. Engage a deadbolt. The Touchpad should read ARMED STAY.
4. Disengage the deadbolt and the system should disarm and turn back off (the Touchpad should read "READY").
5. Open the door. The Touchpad should sound a chime. Repeat for all protected deadbolts in the system.

If there is a problem, see Troubleshooting on page 9. If the signal strength of the Secondary Transmitter is insufficient, clear, re-learn and re-test all transmitters. Re-locate Secondary transmitter if necessary.

24 Close the Transmitter Case

Snap the front of the Transmitter cover onto the base by inserting the 2 slots in the top onto the corresponding tabs on the base and then snapping the bottom into place.

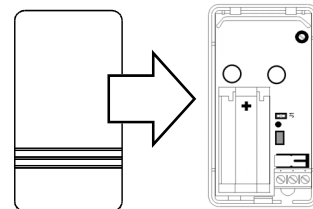

EMERGENCY BUTTON DECALS

Position as follows:

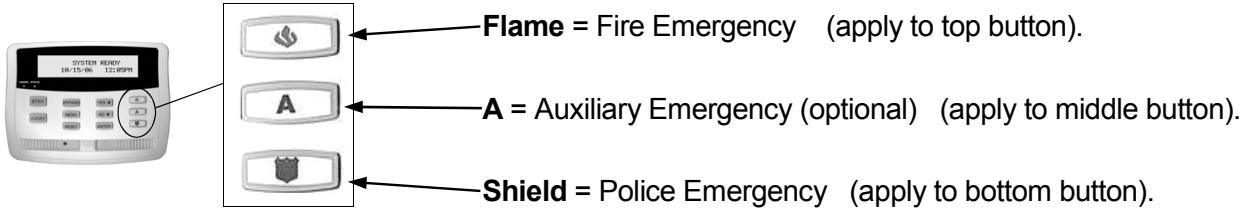

F-64TP TOUCHPAD WIRING DIAGRAM

Freedom F-64 Panel Terminals

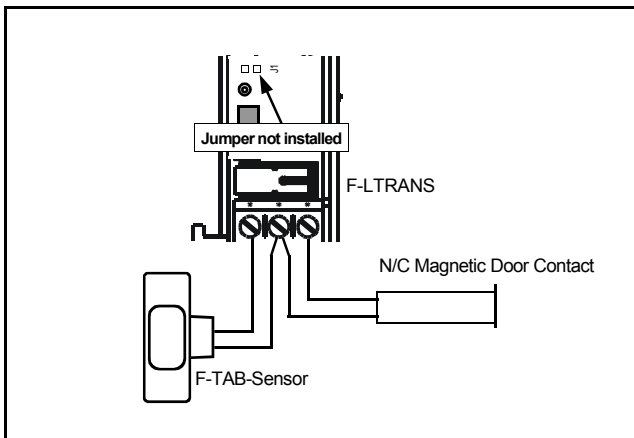
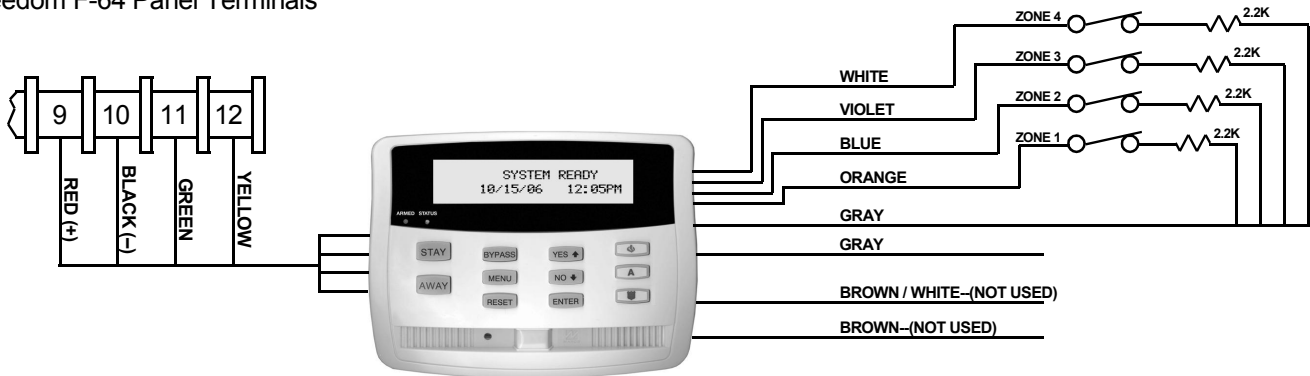

Primary Transmitter

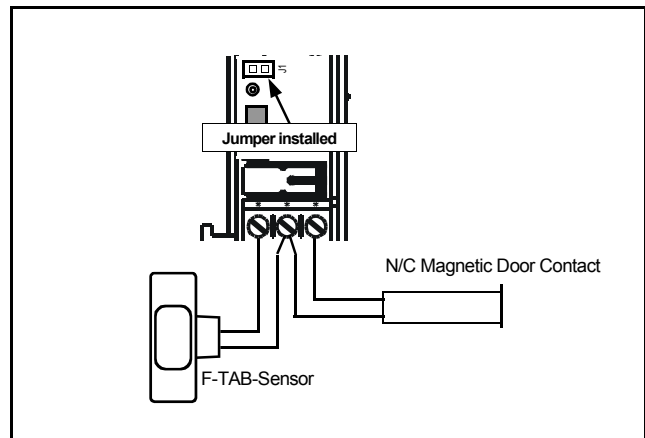

Secondary Transmitter

F-64TP TOUCHPAD PIR

The Touchpad includes an integral PIR sensor which provides the following system functions:

Activity Sensor

The PIR is always gathering activity information which provides the system with data that is used to insure proper use of the system and prevent user errors. For example, if the user presses the AWAY button, opens and closes the door and locks the deadbolt but does not leave, the PIR will sense the user's presence in the home and automatically default to STAY mode arming, preventing a false alarm. If additional PIR sensors are installed, the activity of these sensors will also be included in these decision making processes.

Intrusion Protection Device

When the system is armed AWAY, the PIR provides intrusion protection with a range of 25' at a 90° pattern of protection. An intruder detected in this protected area will cause a Zone 2 alarm (or Zone 8 alarm for TP #2) with a corresponding central station report and audible alarm. **NOTE:** If Touchpad PIR Intrusion Protection is not desired, it may be disabled by installing configuration jumper JP1.2.

Anti-Tamper Protection

The Touchpad PIR also includes 2 side beams which provide tamper protection for the deadbolt. These side beams provide a 170° pattern of protection, which is intended to prevent an intruder from walking along the wall towards the Touchpad and deadbolt. If an intruder is detected in the Anti-Tamper zone, the system will be put into a lockout state for a period of several minutes, during which the system may only be disarmed with an I-FOB. In cases where an extremely large signal is generated in the Anti-Tamper zone, an actual Zone 2 alarm (or zone 8 alarm for TP #2) may occur.

If a Secondary transmitter is installed (used to protect a second door that will be used only for *entry* or to disarm when armed Stay), care must be taken to ensure an intruder can not disarm the system by turning the deadbolt latch at this Secondary transmitter. See **WIRELESS TRANSMITTERS** on page 2 for more information.

NOTE: If there are windows on the wall on which the Touchpad is mounted, they should remain closed while system is armed in order to prevent a draft from causing an Anti-Tamper condition.

- If the deadbolt can be accessed from an area that is not covered by the pattern of protection provided by the Touchpad PIR, then additional protection is required. This may include protecting other doors and windows or additional space protection.
- If the Touchpad is installed adjacent to a door with glass panels or side lights, a glass-break sensor (connected to the Touchpad Aux. Zone) should be installed to insure the integrity of the system.

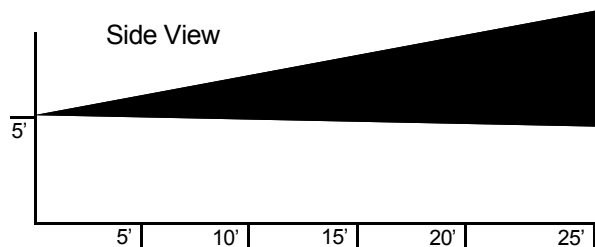
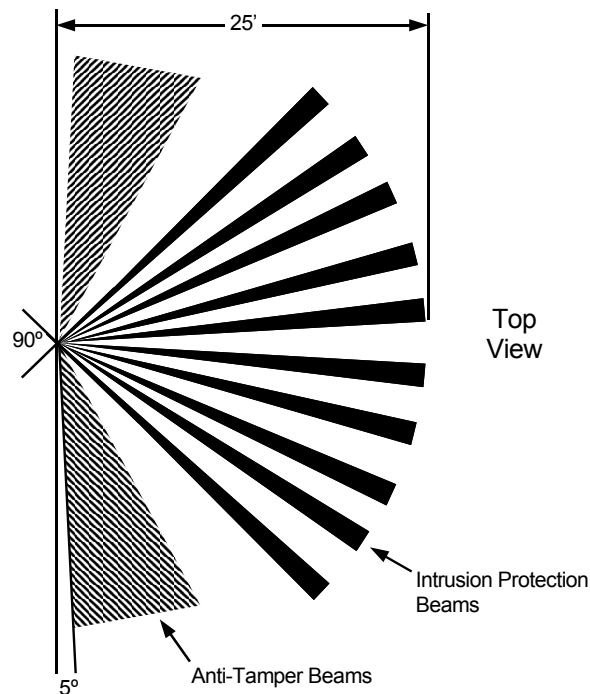

SYSTEM OVERVIEW

FREEDOM F-64 CONTROL PANEL (See W11501 for more information)

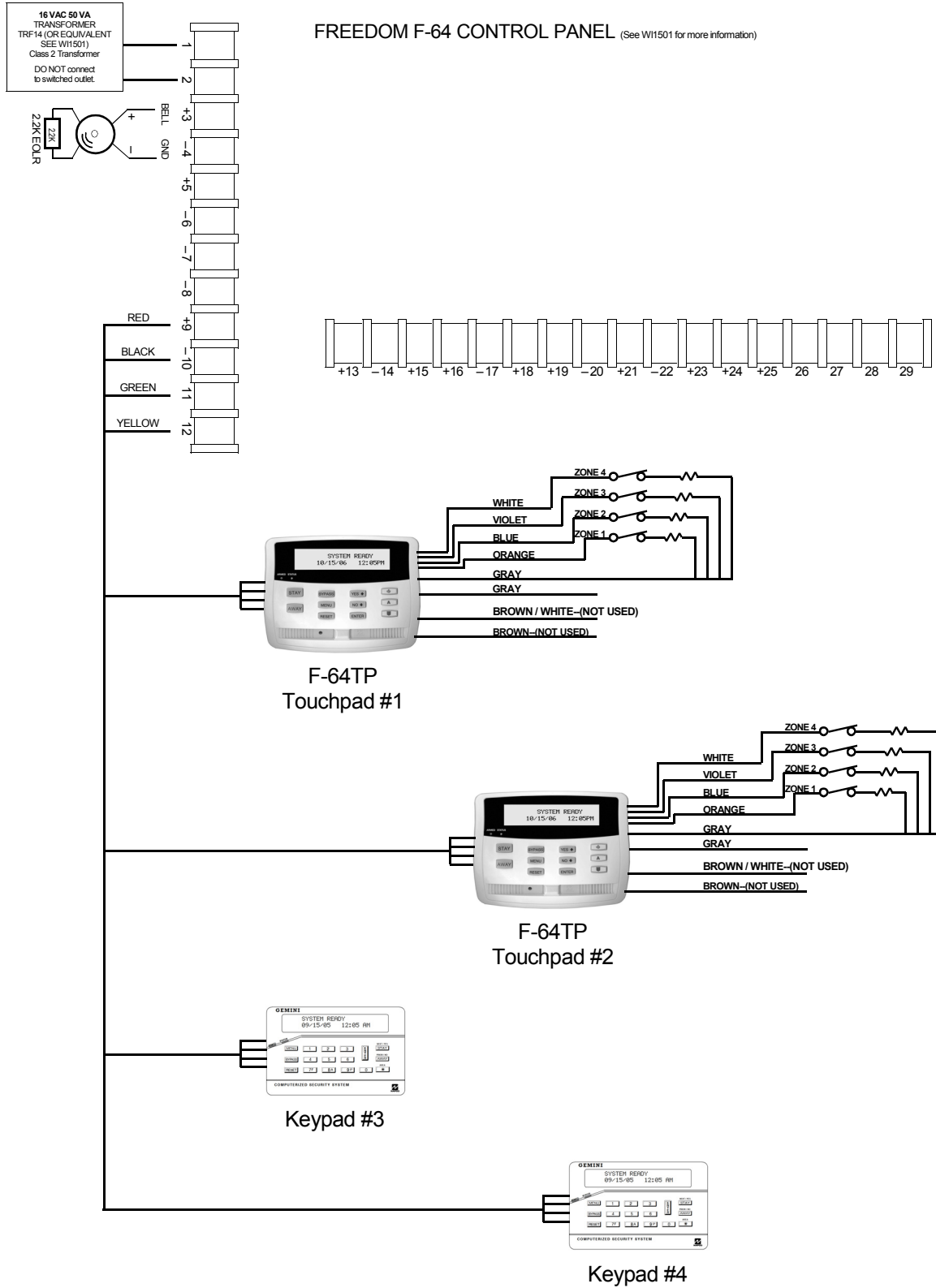

* Multiple Touchpads and keypads must be added contiguously, without gaps. For example, if adding a second Touchpad with two additional keypads, the second Touchpad must be added as Touchpad number 2, with keypads added as numbers 3 and 4. Adding a keypad into slot number 2, with a Touchpad in slot number 3 is not allowed.

TROUBLESHOOTING

TOUCHPAD LIGHTS (ON FRONT OF TOUCHPAD) FAIL TO TURN ON WHEN POWER APPLIED

Check Touchpad power wires (red and black wires).

TOUCHPAD LCD WINDOW DISPLAYS "OUT OF SYSTEM" WHEN POWER APPLIED

Green wire either open or shorted. In addition, if a system trouble appears, the yellow wire is open or shorted.

TOUCHPAD RECEIVER DOES NOT RESPOND TO INCOMING TRANSMISSIONS

Enter **Touchpad Configuration Mode** and select **Display RF SS** to display the signal strength of the enrolled transmitters. A signal strength of zero indicates the transmitter has not been learned; therefore re-learn the transmitter and re-check the signal strength. **Note:** Be sure to remove the transmitter jumper when learning the primary transmitter and remove the jumper when learning the secondary transmitter.

THE TOUCHPAD FAILS TO CHIME* WHEN OPENING THE DOOR:

1. Be sure Chime is enabled by entering the Touchpad Menu Mode. On the Touchpad, press **MENU** until "Deactivate Chime" appears, thus indicating Chime is currently enabled. If "Activate Chime" appears, Chime is currently disabled (press **YES** to enable).
2. Verify the control panel is programmed for Chime to function in the system. Also verify Chime Time is programmed. See W11502 for programming instructions).
3. Check the door contact continuity and door transmitter operation .

Note: Transmitters CANNOT be programmed with their

covers on. Remove transmitter cover to be tested (cover for all other transmitters must be installed).

THE SYSTEM DOES NOT ARM

1. Although the transmitter signal may be received by the Touchpad with a strong signal strength, you must be sure that the zone protected by the transmitter is mapped to the correct zone in the control panel program.
2. On the Touchpad, the green READY light should be on. If the READY light is not on, there is another monitored deadbolt in the system (other than the primary exit door) that is unlocked or a perimeter zone faulted. All other monitored deadbolts must be locked and all zones secured for the system to be able to arm. **Note:** Faulted Zones will scroll in the Touchpad LCD Window.
3. Verify the door contact sensor is not shorted.
4. If no Secondary transmitter is intentionally learned, clear the Touchpad memory and re-learn the transmitter as described in the installation instructions.

Note: Transmitters CANNOT be programmed with their covers on. Remove transmitter cover to be tested (cover for all other transmitters must be installed).

F-LTRANS LED INDICATIONS		
F-LTRANS LED**	Problem	Solution
One flash every 2 seconds	Low battery.	Replace battery.
Two flashes every 2 seconds	F-TAB Sensor Trouble.	The wire to the F-TAB deadbolt sensor is open or shorted, or the F-TAB deadbolt sensor is defective. The wires to terminals 1 and 2 shorted should read about 4 ohms.

* The F-64 Control Panel may be programmed to disable Chime.

** The LED will not flash if the tamper is held down (if cover is on).

MOUNTING TEMPLATE

